

ACCUMULATOR VESSELS
WITH REPLACEABLE OR FIXED BLADDERS



update July 2005



ASME



ASME



EPITÉ SZIGYI
MINŐSÉGELENŐRZŐ
INTÉZET



URZĄD DOZORU
TECHNICZNEGO
POLONIA



STROJIRENSKY ZKUSEBNÍ
ÚSTAV



Accumulator Vessels with replaceable or fixed bladders

<i>AC AS series</i>	6
<i>AF - CE series</i>	8
<i>AFL -CE series</i>	10
<i>Hi-Nox series</i>	12
<i>D - CE series</i>	14
<i>Micron</i>	16
<i>Pressure tank's efficiency</i>	17
<i>Water hammer technical data</i>	17
<i>Instructions for the selection of accumulators</i>	18





**COMPANY
WITH QUALITY SYSTEM
CERTIFIED BY DNV
= ISO 9001/2000 =**

Accumulator vessel with replaceable bladder: definition and operation

The accumulator vessel with replaceable bladder is a device that fitted into a pressurised water system will provide system water at a pre-set, sustained pressure.

Its most common application is to supply systems in which the main supply pressure is too low and a pump is fitted to boost the pressure to an acceptable level.

As system demands take place the accumulator vessel will sustain system pressure by feeding additional water into the system at the required pressure. This process will limit the number of times the pump needs to start (pump hunting) in order that system pressure remains at the optimum level.

The process is achieved by the addition of a pre-charged nitrogen cushion at higher than atmospheric pressure within the vessel shell. This pre-charged cushion is stored between the water bladder and the inner surface of the tank. Any water pressure rise (pumping) causes the cushion to be additionally compressed. As system demands arise the nitrogen cushion forces the water from the bladder into the system thus maintaining optimum system pressure. As the retained pressure finally exhausts and system pressure falls a pressure switch will turn the pump on, re-pressurising the system and the accumulator ready for further use.

This way the accumulator will prevent the need for the pump to start every time there is a demand on the water system and will flatten the system pressure curve at the optimum pressure.

Elbi accumulator vessels with replaceable bladders are the result of 30 years of experience in the design, manufacture and installation of tanks in hydraulic systems. The range is currently the most complete on the market in terms of product availability. The range has been subdivided into various series, each of which is designed for the various applications required by modern systems technology.

All the products have been designed to comply with the most stringent international standards, mainly through the use of the latest design technology and industrial automation. The Elbi plants are on the edge of technological solutions with regard to design, production, automated welding and robot manufacturing systems.

All manufacturing processes are carried out within the Elbi plant facilities, including bladder production, which is critical as it determines the operation, life cycle and performance of the finished product. Elbi accumulators with replaceable bladder are manufactured from the highest quality UNI standard steel plate and welded using certified materials and procedures.

The versions for water-pressurisation systems, comprising the AS, AC, AF and AFL series, come in capacities ranging from 2 to 5000 litres. All the models have been designed to hold potable (drinking) water and each features specific technical options to prevent the liquid from coming in contact with the inner surface of the tank. Over the years Elbi has become one of the undisputed leaders in the achievement of stringent quality standards in terms of its sanitary procedures.

Both the AF and AFL series, available in 10 bar versions, are best suited to be fitted in systems designed to limit over-pressure.

Elbi's decades of experience in international markets has led to the manufacture of products that comply with a wide range of international regulations. Alongside standard models, customised configurations compliant with ASME, BS, CE and TÜV standards are also available.

Elbi accumulators with replaceable bladders also come in tailored-made versions that reflect the latest evolution of the market. Special attention paid to emerging consumer requirements has led to the implementation of the HI-NOX series, entirely made up of stainless alloy with MIG welded seams. These vessels are particularly suited for use in aggressive environments (sea, corrosive, etc.). The technical solutions used during design of these vessels make the HI-NOX series a reference standard for bladder-equipped tanks.

Financial benefits

Unlike standard air-cushioned accumulators without bladder, the accumulators with bladders feature the following advantages:

- **energy saving** reduced number of pump start-ups;
- **installation cost reduction** lack of water contact means that air is no longer dispersed into the water and therefore, there is no further need to supply a compressor to restore the cushion;
- **maintenance costs reduction** only the tank pre-charge pressure has to be checked. Additionally the bladder can be replaced, disassembled and reassembled easily in a very short time;
- **stored volume reduction** space saving;
- **water contamination risk is reduced** the bladder also serves as protection against any substance suspended in the air, such as: oil, smoke, bacteria, smells, dust, etc. that may alter the quality of water. Bladders are certified for alimentary use;
- **long-lasting tank** the fact that the bladder prevents water from being in direct contact with the inner surface of the tank significantly reduces corrosion;
- **dual purpose** this type of tank will also cushion water hammer.

AS - AC series

from 5 to 24 litres



The AS AC series replaceable bladder accumulators come in models with a 5 to 35 litres capacity and provide for small-sized domestic systems, garden irrigation systems and any other application requiring smaller delivery capacities. All the models are equipped with standard EPDM bladders that allow them to be used as expansion vessels for sanitary use.

The AS-25 model, both practical and inexpensive, is suited for fitting directly on the pump. The AC GMP-25 model has been designed to implement small, compact-type, pressurisation units. CE certified.

Characteristics:

- Long-lasting epoxy paint finish to ensure greater protection against atmospheric corrosion.
- Complete separation between water and air; no contact between water and the inner surface of the tank;
- Non toxic replaceable bladder for alimentary use, flexible enough to allow full expansion inside the tank, thus, enhancing performances and ensuring a longer product life cycle;
- Working temperatures: $-10^{\circ} \div +99^{\circ}\text{C}$ (model AC 20 PN25: $-10^{\circ} \div +50^{\circ}\text{C}$);
- In compliance with essential safety requirements of directive 97/23/EC
- CE marking (type AC 5 without CE marking)

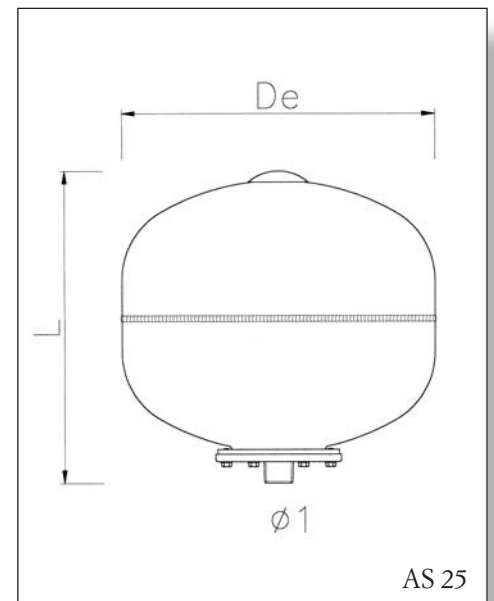

Type	Capacity litres	Working pressure bar	Precharge pressure bar	ø1	De mm	L mm	H mm	Packaging mm
AC 5	5	8	1.5	3/4"	205	240	-	210 x 210 x 250
AC 8 CE	8	8	1.5	3/4"	205	315	-	210 x 210 x 320
AC 18 CE	18	8	1.5	3/4" - 1"	270	430	-	280 x 280 x 450
AC 20 PN25	20	25	5	3/4" - 1"	270	485	-	280 x 280 x 500
AC 25 CE	24	8	1.5	3/4" - 1"	270	470	-	280 x 280 x 470
AFV 24	24	16	1.5	3/4" - 1"	270	470	-	280 x 280 x 470
AC 25 GPM CE	24	8	1.5	3/4" - 1"	270	470	290	280 x 300 x 470
AS 25 CE	24	8	1.5	3/4" - 1"	360	365	-	360 x 360 x 380

Bladder accumulator selection chart

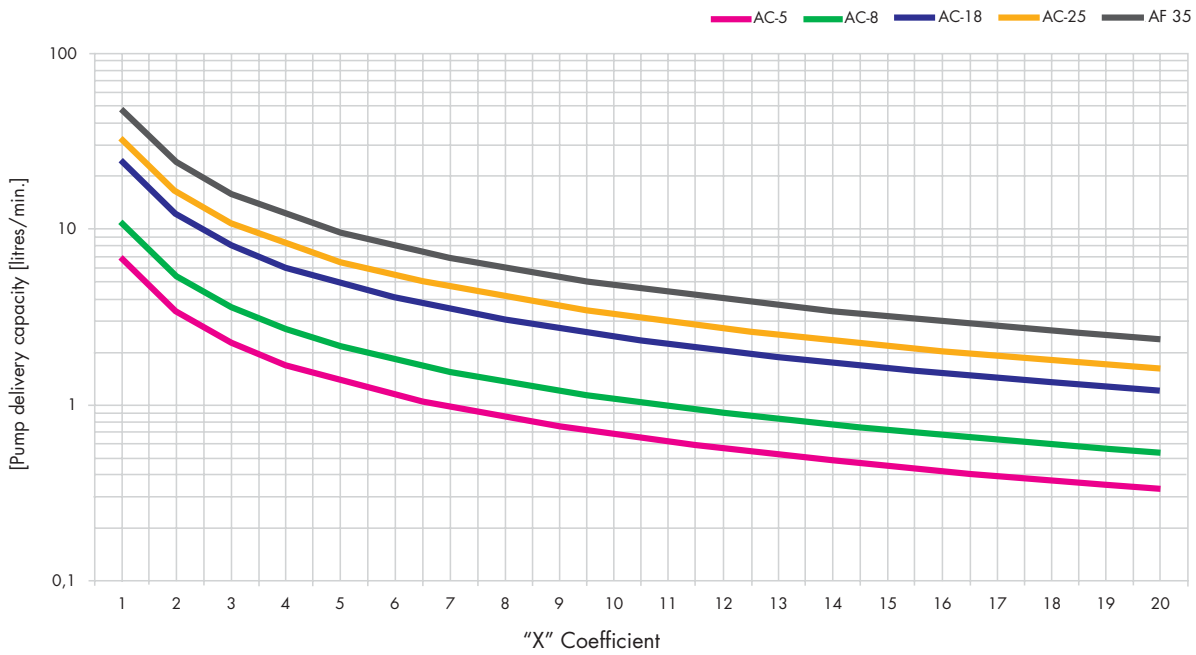

To make sizing easier, a chart has been drawn up to select the most appropriate accumulator according to both the working pressure and delivery criteria. Note that the chart is based on the following hypothesis: standard precharge and 15 pump starts per hour (see p.19 to identify the "X" coefficient).

Pump maximum delivery capacity [litre/min.]	Δp operating pressures											
	1,5 ÷ 3,0			2,0 ÷ 3,5			2,5 ÷ 4,0			2,0 ÷ 4,0		
	Number of pump starts per hour											
	15	8	5	15	8	5	15	8	5	15	8	5
2	5	8	18	8	18	24	8	18	35	5	8	18
8	18	35	50	24	50	80	80	35	100	24	50	80
10	24	50	60	35	60	100	100	50	150	35	50	100

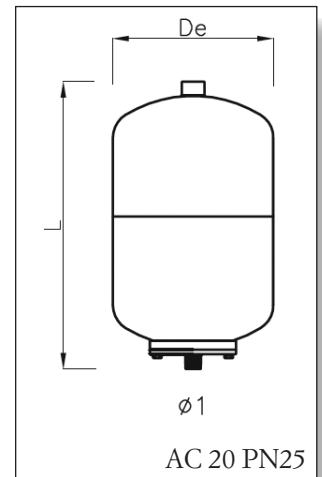
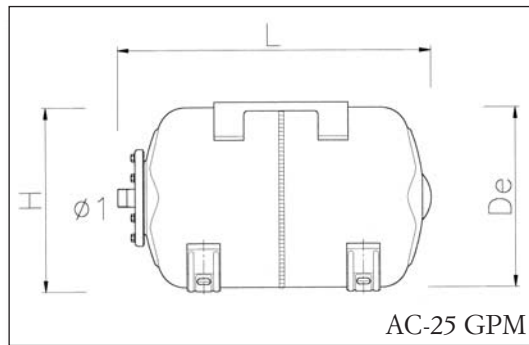
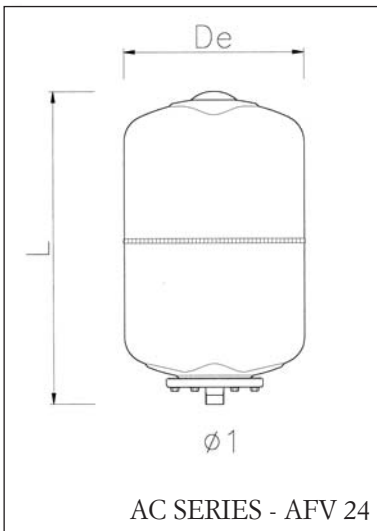

AF - CE series

from 35 to 500 litres



The AF series replaceable bladder accumulators come in models with a 35 to 500 litres capacity, and are best suited for residential and industrial systems requiring substantial delivery capacities.

Supplied in the CE certified version, the AF series accumulators are also available in customised versions compliant with major international standards. The horizontal version is provided with universal motor-support brackets to allow the pump to be directly fastened above the vessel.



Characteristics:

- Sturdy construction in prime quality long life steel.
- Non toxic replaceable bladder for alimentary use, flexible enough to allow full expansion inside the tank, thus, enhancing performances and ensuring a longer product cycle.
- Long-lasting epoxy paint treatment to ensure greater protection against atmospheric corrosion.
- Complete separation between water and air;
- No contact between water and the inner surface of the tank;
- Working temperatures: $-10^{\circ} \div +99^{\circ}\text{C}$.
- In compliance with essential safety requirements of directive 97/23/EC;
- CE marking;

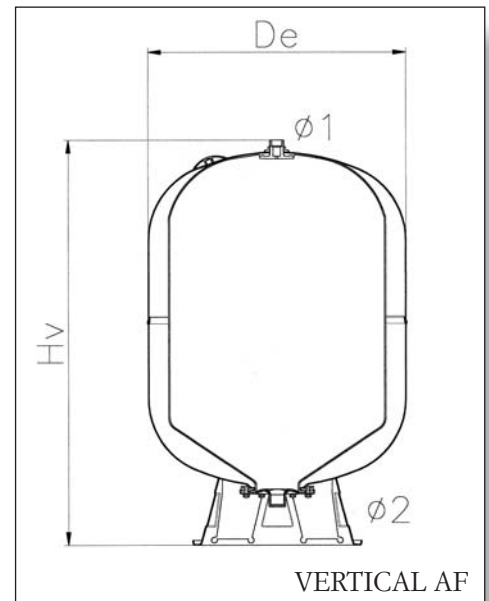

Type	litres	Work. Pres. bar	Prec. Pres. bar	De mm	Hv mm	Ho mm	L mm	ø1	ø2	Packaging		
										vertical mm	horizontal mm	
AF 35	35	10	-	1.5	400	-	-	400	-	3/4" - 1"	410x410x410	-
AF 50	50	10	-	1.5	400	600	425	515	-	1"	410x410x610	410x530x440
AF 60	60	10	-	1.5	400	750	480	675	1/2"F - 3/4" M	1"	410x410x760	410x685x490
AF 80	80	10	-	1.5	400	815	480	765	1/2"F - 3/4" M	1"	410x410x860	410x775x490
AF 100	100	10	16	1.5	500	805	585	720	1/2"F - 3/4" M	1"	510x510x830	510x730x600
AF 150	150	10	-	1.5	500	1030	-	-	1/2"F - 3/4" M	1" 1/4	510x510x1040	-
AF 200	200	10	16	1.5	600	1065	665	970	1/2"F - 3/4" M	1" 1/4	610x610x1110	610x950x680
AF 300	300	10	16	1.5	650	1270	705	1130	1/2"F - 3/4" M	1" 1/4	660x660x1290	660x1140x720
AF 500	500	10	-	1.5	775	1420	-	-	1/2"F - 3/4" M	1" 1/4	785x785x1440	-

1 MPa = 10 bar

AFL - CE series

from 750 to 5000 litres



The AFL series replaceable bladder accumulators provide a response to the problems of installation in large capacity systems that up until today required either the use of standard accumulators without bladder or the installation of a series of small-sized tanks.

Installing AFL series tanks considerably cuts down both installation and maintenance costs.

The AFL series come in models with a 750 to 5000 litres capacity thanks to a truly exclusive bladder design.

The AFL series bladders are virtually indestructible since they were built to operate without stretching, even in high-pressure conditions or air cushion leakage.

Supplied in 10 bars export versions, 10 bars certified CE versions and special ASME versions.

Additionally, tailored-made configurations are also available for high-pressure systems (up to 16 bars) and horizontal versions are available upon request.



Characteristics:

- Sturdy construction in prime quality, long life steel.
- Complete separation between water and air;
- No contact between water and the inner surface of the tank;
- Non toxic replaceable bladder for alimentary use exclusively designed and manufactured by Elbi.

The dimensions of the AFL series bladders reproduce the pitch volume of the tank, thus, allowing the bladder to operate without stretching and making it virtually indestructible.

- Top-Pro® internal protection against corrosion (from AFL750 thru AFL5000).
- Working temperatures: -10° ÷ +50°C.
- In compliance with essential safety requirements of directive 97/23/EC.
- CE marking.

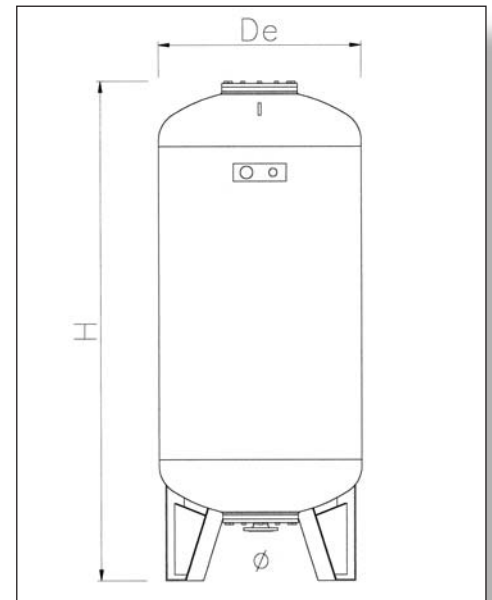

Model	Capacity Litres	De mm	H mm	ø	Max. working pressure (bar)
AF 500	500	650	1870	1" 1/4 M	- 16
AFL 750	750	800	1960	2" M	10 16
AFL 1000	1000	800	2340	2" M	10 16
AFL 2000	2000	1100	2750	G 3"	10 16
AFL 3000	3000	1250	3100	G 3"	10 16
AFL 5000	5000	1550	3420	G 3"	10 -

Bladder accumulator selection chart

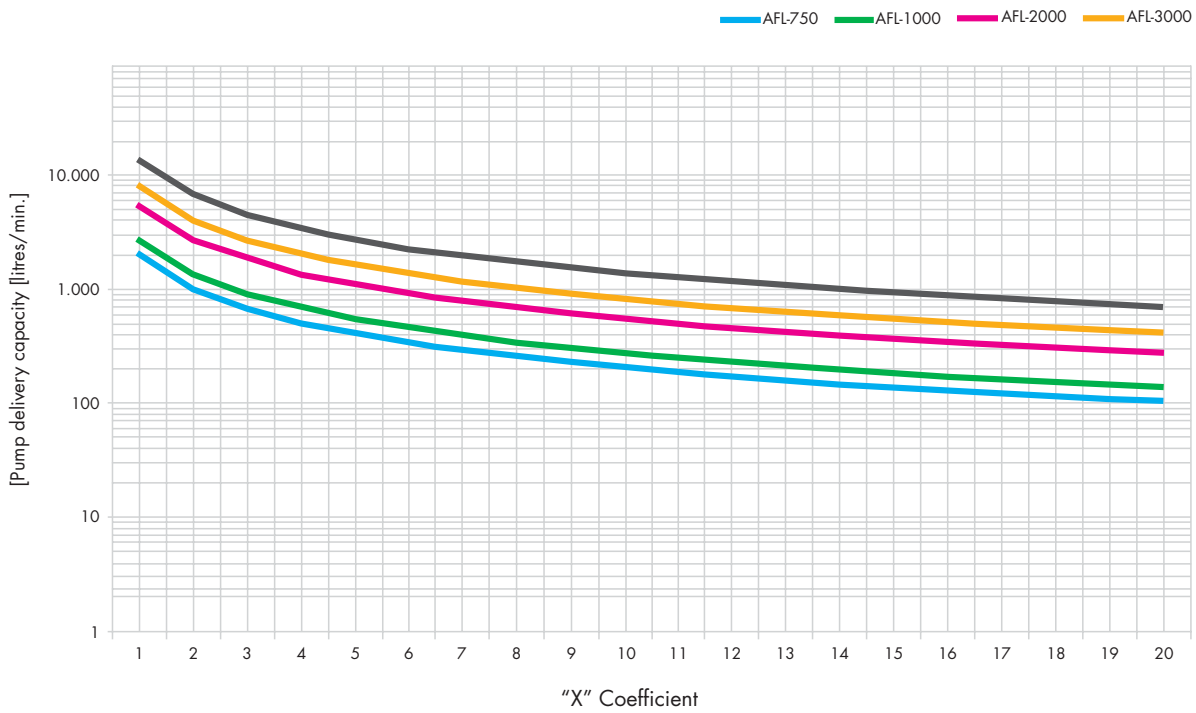

To make sizing easier, a chart has been drawn up to select the most appropriate accumulator according to both working pressure and delivery criteria. Note that the chart is based on the following hypothesis: standard precharge and **15 pump starts per hour** (see p.19 to identify the "X" coefficient).

Pump max. deliv. Capac. [litres/min.]	Δp operating pressures											
	1,5 ÷ 3,0			2,0 ÷ 3,5			2,5 ÷ 4,0			2,0 ÷ 4,0		
	Number of pump starts per hour											
	15	8	5	15	8	5	15	8	5	15	8	5
75	200	300	500	250	500	750	300	750	1000	250	500	750
95	200	500	750	300	750	1000	500	1000	2x750	300	500	1000
115	250	500	750	500	750	1000	500	1000	2x750	300	750	1000
150	300	750	1000	500	1000	2x750	750	2x750	2000	500	1000	2x750
200	500	1000	2x750	750	2x750	2000	1000	2000	3000	750	2x750	2000
300	750	2x750	2000	1000	2000	3000	2x750	3000	2x2000	1000	2x750	3000
500	2x750	2000	3000	2000	3000	5000	3000	5000	5000+3000	2x750	3000	2x2000
800	2000	3000	5000	3000	5000	4x2000	2x2000	5000+3000	2x5000	2000	2x2000	5000+2000
1000	2000	2000	2x3000	2x2000	2x3000	2x5000	5000	2x5000	3x5000	3000	5000	5000+3000

HI-NOX series

from 2 to 60 litres



These stainless steel pressure vessels represent the top of the Elbi range in terms of quality. Designed as stand-alone units, and not just as a stainless steel version of the more standard carbon steel products, the HI-NOX expansion vessels are manufactured using all the specific techniques and equipment required of stainless steel. Special attention has also been paid to the polishing of the products and aesthetic features in general.

12

The HI-NOX range comes in different versions in order to meet all the application requirements for that type of products

- The fixed-bladder HX-2 model is particularly suited as a water hammer damper.
- The replaceable bladder HM and HM-GPM models are definitely recommended for small water pressurisation units where the quality and sanitation of water is of paramount importance;
- Similarly in style to the painted steel standard version, the HM-GPM-24 model has been designed to implement smaller, compact-type, water pressurisation units;
- All the HI-NOX series expansion vessels come standard-equipped with EPDM bladders (Type HX2 with butyl bladder).

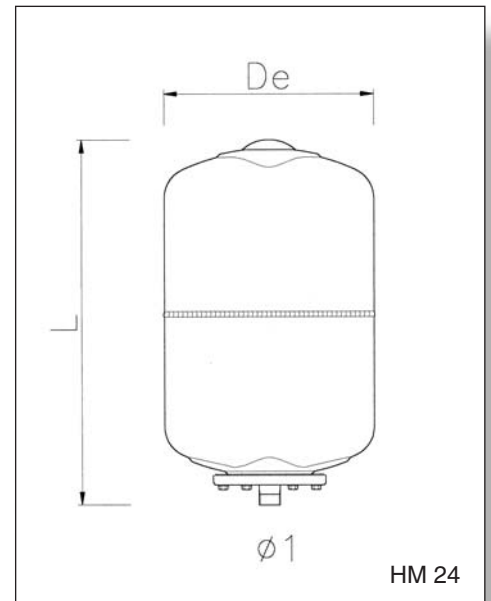

Type	Capacity litres	Working pressure bar	Precharge pressure bar	Operating temperature °C	De	H mm	L mm	ø1	Packaging mm
HX 2	2	10	3,5	99	146	230	-	1/2"	148x148x238
HS 24	24	10	1,5	99	360	365	-	3/4"	360x360x380
HM 24	24	10	1,5	99	270	470	-	1"	280x280x480
HM GPM 24	24	10	1,5	99	270	290	470	1"	280x480x300
HM 60 V	60	10	1,5	99	400	795	-	1"	410x410x800
HM 60 H	60	10	1,5	99	400	480	675	1"	410x685x495

1 MPa = 10 bar

Bladder accumulator selection chart

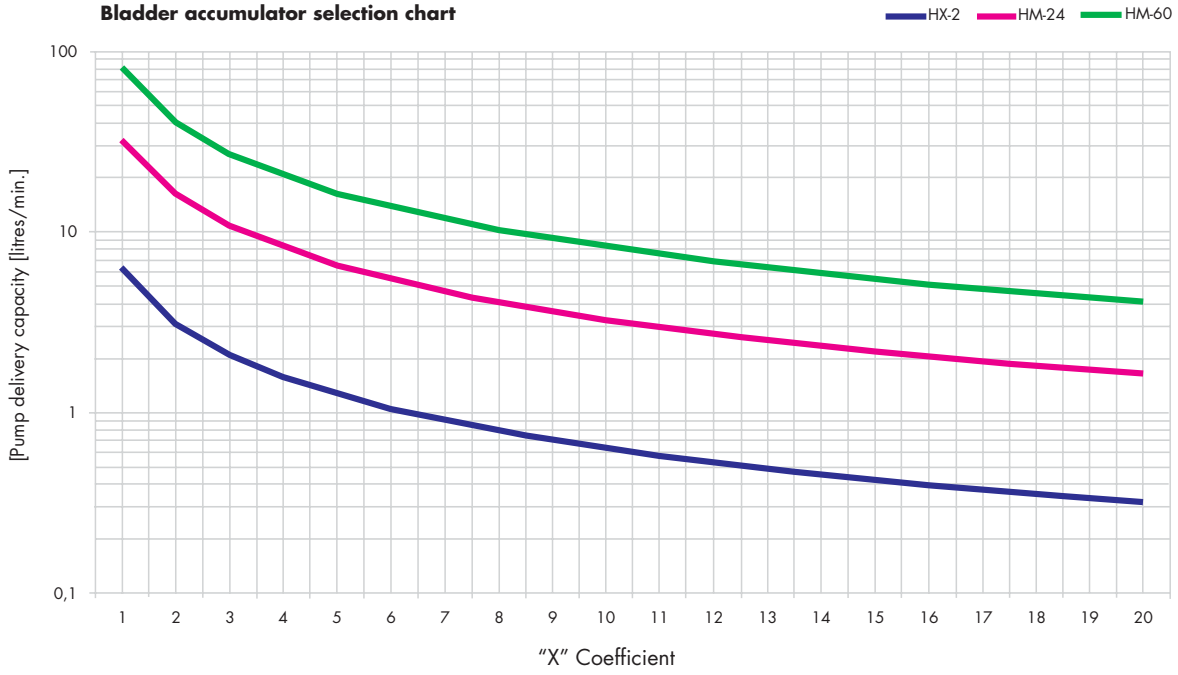

To make sizing easier, a chart has been drawn up to select the most appropriate accumulator according to both working pressure and delivery criteria. Note that the chart is based on the following hypothesis: standard precharge and **15 pump starts per hour** (see p.19 to identify the "X" coefficient).

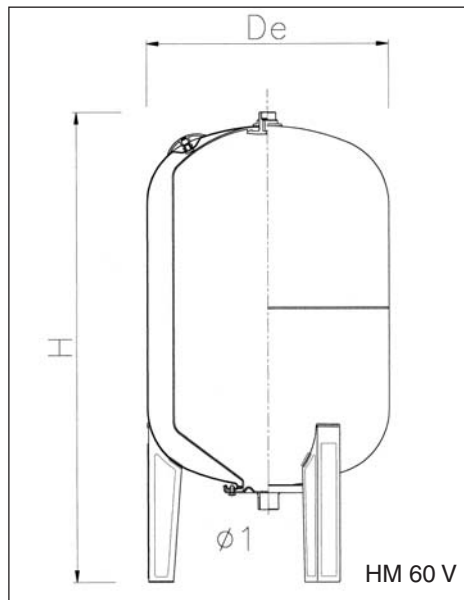
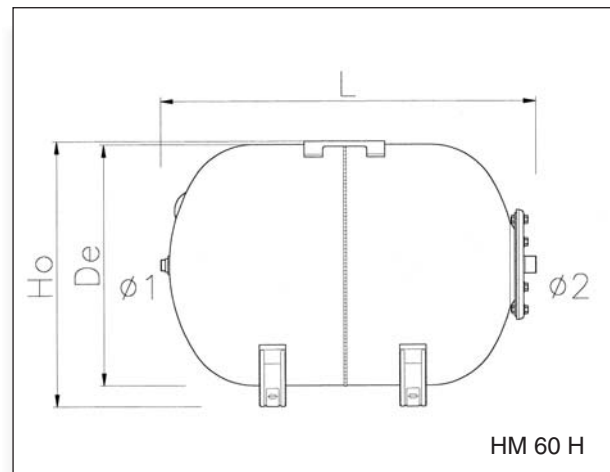
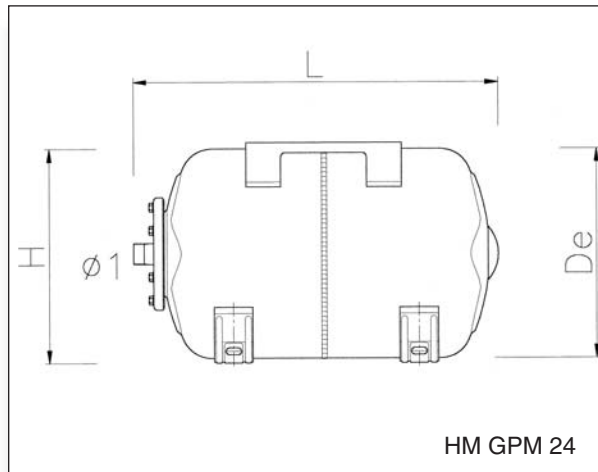
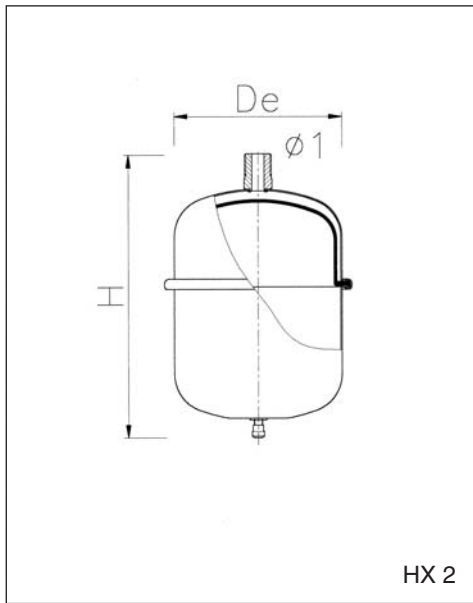

D - CE series

from 2 to 500 litres



Multifunctional sanitary vessels with fixed bladder

Multifunctional sanitary vessels with fixed bladder are designed to be fitted both into sanitary systems as expansion tanks, suitable to absorb the water expansion volume generated by a changing temperature, as well as pressure tanks for cold water sanitary systems.

Both applications are possible thanks to the exclusive Top-Pro® anti-corrosion treatment which ensures the protection against corrosion of the inner surface of the tank and the fitness of all parts in contact with water.

Installing a D series sanitary vessel considerably cuts down operating costs, while suppressing the discharge function of the safety valve.

Characteristics

- Equipped with a fixed alimentary bladder in Butyl that ensures permanent isolation of the air cushion from the water;
- Internal protection of the water connection in NYLON 66;
- Guaranteed for 3 years (all the D series);
- In compliance with essential safety requirements of directive 97/23/EC;
- CE marking (Type D2 and D5 without CE marking).

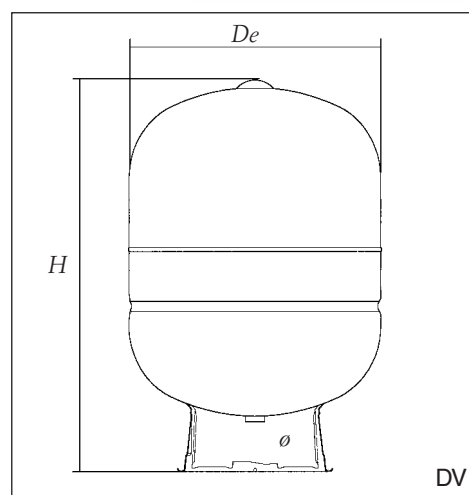
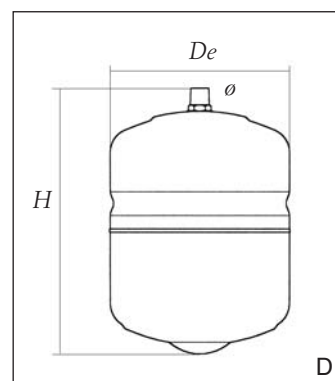

Model	Capacity litres	Max working pressure (bar)	Ø	De mm	H mm	Air precharge (bar)	Packaging (mm)
D2	2	10	1/2"	146	230	3	150 x 150 x 240
D5	5	10	3/4"	205	225	3	210 x 210 x 250
D 8	8	10	3/4"	205	300	3	210 x 210 x 320
D 11	11	10	3/4"	270	300	3	280 x 280 x 310
D 18	18	10	3/4"	270	410	3	280 x 280 x 450
D 24	24	10	1"	320	355	3	330 x 330 x 375
D 35	35	10	1"	400	390	3	410 x 410 x 410
DV 50	50	10	1"	400	570	3	410 x 410 x 610
DV 80	80	10	1"	400	825	3	410 x 410 x 860
DV 100	100	10	1" 1/4	500	779	3	510 x 510 x 830
DV 150	150	10	1" 1/4	500	1.007	3	510 x 510 x 1040
DV 200	200	10	1" 1/4	600	1.076	3	610 x 610 x 1110
DV 300	300	10	1" 1/4	650	1.251	3	660 x 660 x 1290
DV 500	500	10	1" 1/4	775	1.410	3	785 x 785 x 1440

Bladder accumulator selection chart

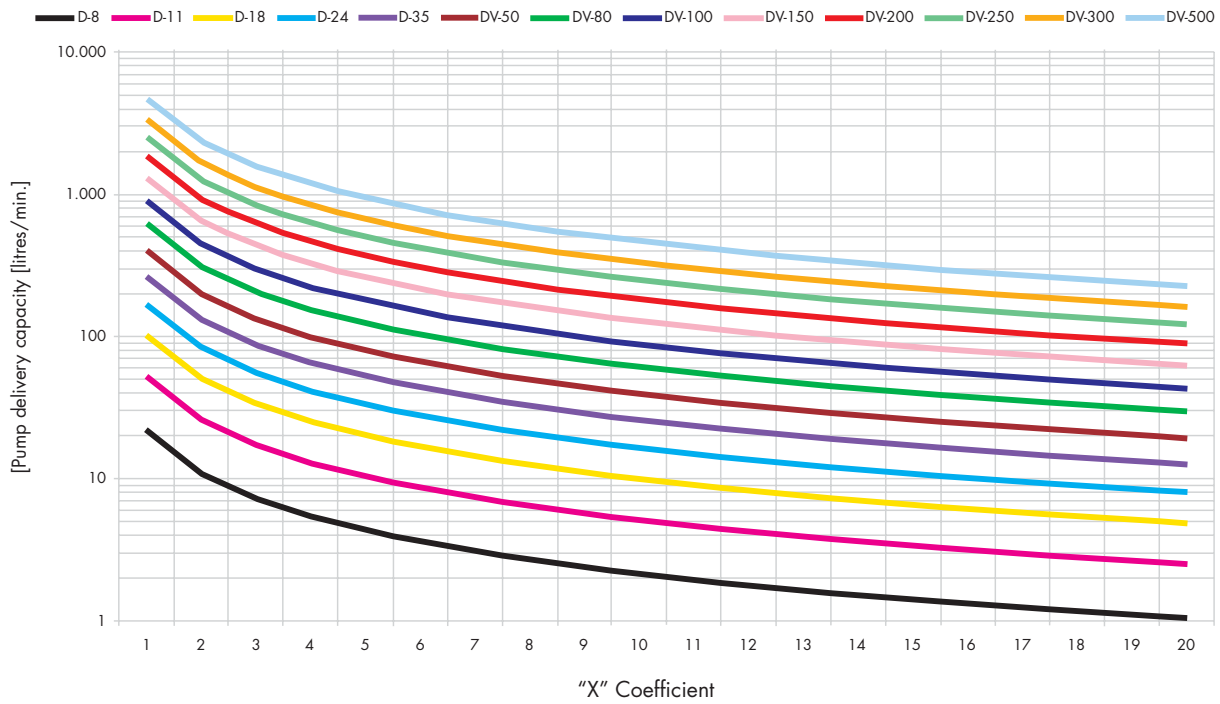

To make sizing easier, a chart has been drawn up to select the most appropriate accumulator according to both working pressure and delivery criteria. Note that the chart is based on the following hypothesis: standard precharge and 15 pump starts per hour (see p.19 to identify the "X" coefficient).

Pump max delivery capacity [litres/min.]	Δp operating pressures								
	1,5 ÷ 3,0			2,0 ÷ 3,5			2,5 ÷ 4,0		
	Number of pumps starts per hour								
	15	8	5	15	8	5	15	8	5
10	D-35	DV-50	DV-50	D-35	DV-50	DV-80	D-35	DV-50	DV-80
20	DV-50	DV-80	DV-100	DV-80	DV-100	DV-150	DV-80	DV-100	DV-150
25	DV-80	DV-100	DV-150	DV-80	DV-150	DV-150	DV-100	DV-150	DV-200
40	DV-100	DV-200	DV-200	DV-150	DV-200	DV-300	DV-150	DV-200	DV-300
45	DV-150	DV-200	DV-300	DV-150	DV-200	DV-300	DV-150	DV-300	DV-300
55	DV-150	DV-300	DV-300	DV-200	DV-300	DV-500	DV-200	DV-300	DV-500
75	DV-200	DV-300	DV-500	DV-300	DV-500	DV-500	DV-300	DV-500	DV-500
95	DV-300	DV-500	DV-500	DV-300	DV-500	2xDV-300	DV-500	DV-500	2xDV-500
115	DV-300	DV-500	2xDV-300	DV-500	2xDV-300	2xDV-500	DV-500	2xDV-300	2xDV-500

Micron

160 ml

Water hammer-arrestor

The Micron small vessel is designed to absorb sudden overpressure caused by water hammer in pressurised hydraulic systems. Using the Micron small vessel tends to suppress both the noise and vibrations generated by the above phenomena, thus, increasing the life of the system.

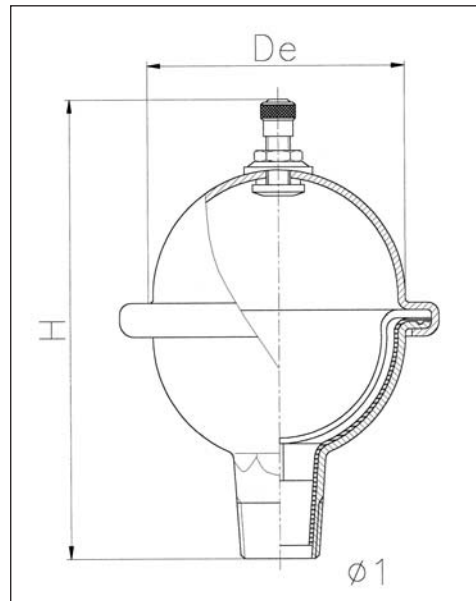

16

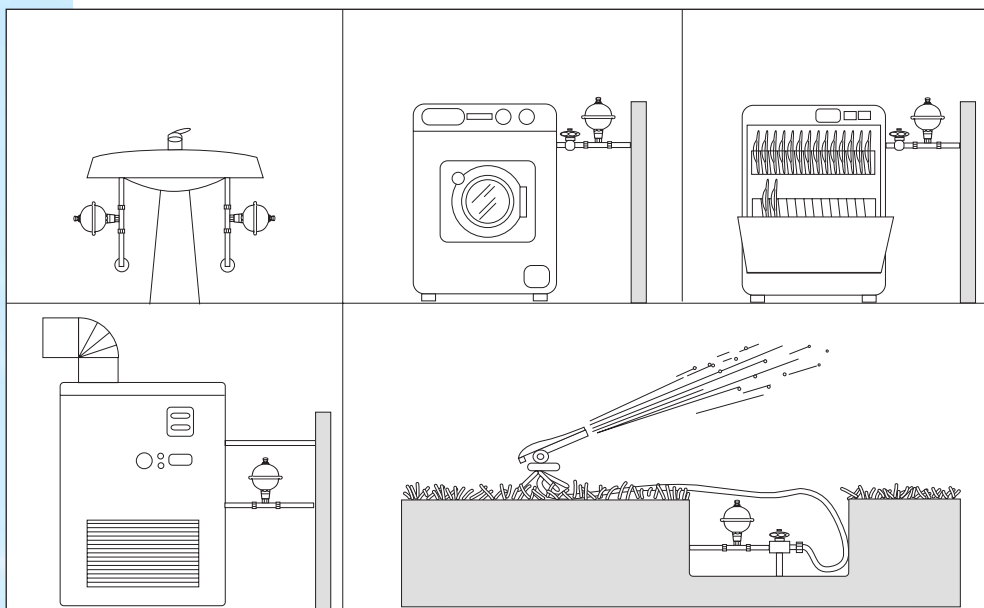

Type	Capacity ml	Max temperature °C	Maximum pressure bar	Precharge pressure bar	De mm	H mm	Ø	Packaging 8 pieces mm
MICRON	160	99	10	3,5	88	121	1/2"	270x270x180

1 MPa = 10 bar

Pressure tank's efficiency (draw-down)

The efficiency of the pressure tank is the quantity of water (draw-down) that the tank can provide between a max (p2) and a min (p1) working pressure of the pump.

Called:

- Va = total volume of the pressure tank
- p1 = switch (on) of the pump
- p2 = switch (off) of the pump
- pc = air precharge pressure

NOTE: All pressure are referred to as gauge pressure.

The formula to calculate the efficiency of the tank is as follows:

$$R = \frac{(p2 - p1) \times (pc + 1)}{(p2 + 1) \times (pc + 1)} \times Va; \quad \text{Stated } pc = p1$$

$$R = \frac{(p2 - p1)}{(p2 + 1)} \times Va$$

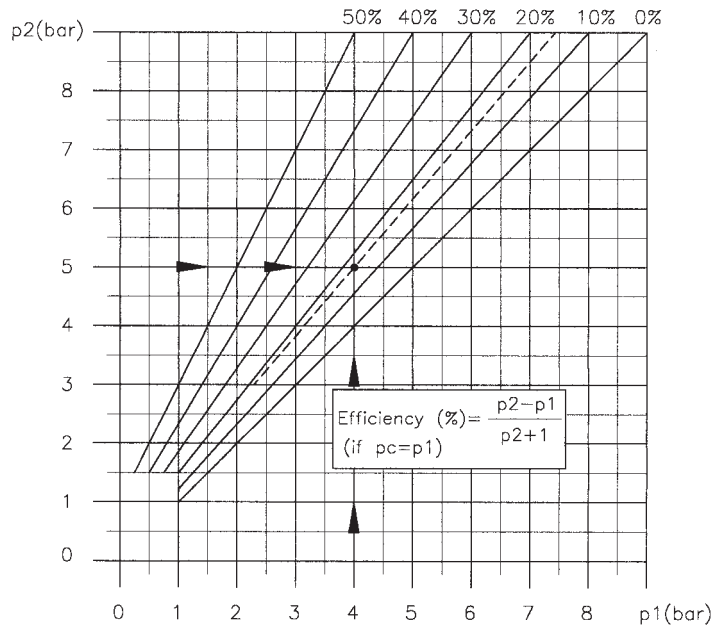

Fig. 1: Table of efficiency

Example:

Va = 750 lt. P1 = 4 bar p2 = 5 bar pc = p1 = 4 bar

The efficiency of the tank is: $R = \frac{(5 - 4)}{(5 + 1)} \times 750 = 125 \text{ lt}$, that's 16%

The table of efficiency (Fig. 1) shows the efficiency in % according to the min. and max. working pressures of the pump.

Water hammer: technical data

Water hammer (overpressure shock) is caused by the sudden closing of a valve or similar device in a hydraulic system. The sudden closure causes a sonic pressure wave to travel backward through the pipe system. As the pressure wave hits obstructions in the system, additional pressure waves are reflected back in the opposite direction. These pressure waves will cause loud noises within the system and can lead to physical damage and short system life if left unchecked.

To overcome this problem the system must be equipped with a hydraulic shock absorber able to absorb the pressure wave through the use of an air cushion. The Micron hammer arrestor is the perfect device for this purpose.

Installation examples of pressure tanks used as shock hammer absorbers:

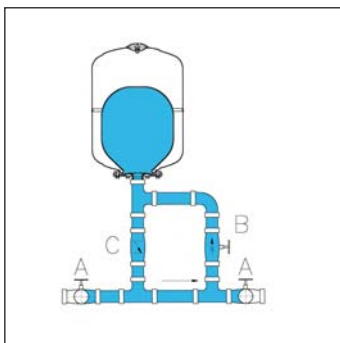

Constant pressure

The "A" valves are open and the water rate of flow inside the pipeline is constant. During this phase, the vessel gradually fills up until the pressure becomes identical to the systems.

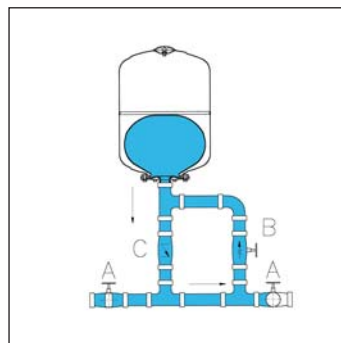

Case Nr. 1

Whenever the "A" valve upstream suddenly shuts down, the water column inside the pipeline follows its course and, in order to avoid a pressure drop at the valve output, i.e. a narrowing of the pipeline, the "C" check valve opens to release part of the stored water.

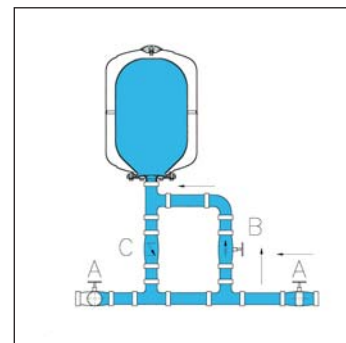

Case Nr. 2

Whenever the "A" valve downstream suddenly shuts down the water column inside the pipeline preceding the valve creates a pressure wave. This wave reverberates throughout the pipeline; in this case, water can only pass through the "B" narrowing valve, which cushions the water hammer, gradually filling up the vessel in the process.

Once the total charge units have been computed, turn them into litres per minute by referring to table 3.

Tab 3

CONVERSION TABLE (Litres/min.)					
UC	Q [lt/min]	UC	Q [lt/min]	UC	Q [lt/min]
6	18	100	189	1250	930
8	24	120	219	1500	1050
10	30	140	234	1750	1128
12	36	160	255	2000	1230
14	40.8	180	276	2250	1320
16	46.8	200	297	2500	1410
18	51	225	321	2750	1470
20	55.8	250	345	3000	1560
25	67.8	275	366	3500	1680
30	78	300	387	4000	1830
35	87.6	400	468	4500	1950
40	97.2	500	540	5000	2070
50	114	600	600	6000	2280
60	132	700	660	7000	2460
70	144	800	714	8000	2640
80	159	900	774	9000	2820
90	174	1000	828	10000	3000

Once the system maximum consumption (Q_{max}) has been defined, proceed to size the accumulator by applying the corresponding formula.

"X" coefficient

PUMP STOP PRESSURE (bar) (max)	PUMP STARTING PRESSURE (bar) (min)					
	0.5	1	1.5	2	2,5	3
1	1					
1.5	0.7	3				
2	0.66	2	6			
2.5	0.62	1.66	3.75	10		
3	0.6	1.5	3	6	15	
3.5	0.58	1.4	2.65	4.66	8.75	21
4	0.57	1.33	2.4	4	6.66	12
4.5	0.56	1.28	2.25	3.6	5.62	9
5	0.55	1.25	2.14	3.33	5	7.5
5.5	0.55	1.22	2.06	3.14	4.58	6.6
6	0.54	1.2	2	3	4.28	6
6.5	0.541	1.181	1.95	2.88	4.06	5.57
7	0.538	1.16	1.90	2.8	3.88	5.25
7.5	0.53	1.15	1.87	2.72	3.75	5
8	0.53	1.14	1.84	2.66	3.63	4.8



Elbi S.p.A. via Buccia, 9 - 35010 Limena (pd) ITALY phone +39 049 8840677 - fax +39 049 8841610
Internet: <http://www.elbi.it> • e-mail: info@elbi.it