

## ARTICULO: 2232N

### Válvula de Compuerta Clase 800 extremos roscados. Threaded ends Gate Valve Class 800.

#### Características

1. Válvula de compuerta clase 800.
2. Diseño según EN ISO 15761 (API 602).
3. Construcción en Acero Forjado ASTM A105.
4. Asiento inoxidable endurecido con Stellite.
5. Compuerta Inoxidable.
6. Trim # 8 (equivalente XU).
7. Extremos roscados según ASME B1.20.1 NPT.
8. Bonete atornillado.
9. Presión Máxima de trabajo 140 Bar.
10. Temperatura Máxima de trabajo: 420 °C.

#### Features

1. Gate valve Class 800.
2. Design according to EN ISO 15761 (API 602).
3. Made by Forged Steel ASTM A105.
4. Hardened stainless steel seat with Stellite.
5. Wedge Disc made of Stainless Steel.
6. Trim # 8 (equivalent to XU).
7. Threaded ends according to ASME B1.20.1 NPT.
8. Bolted Bonnet.
9. Max. Working pressure 140 Bar.
10. Max. Working temperature 420 °C.

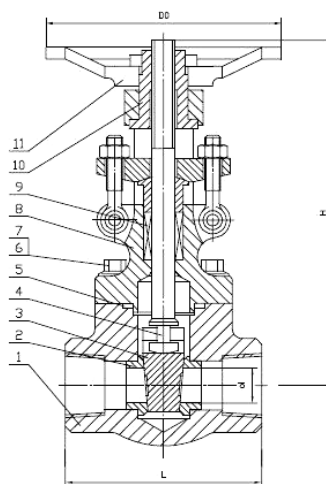

Nº	Denominación / Name	Material	Acabado Superficial / Surface Treatment
1	Cuerpo / Body	ASTM A105	Fosfatizado / Phosphatized
2	Asiento / Seat	ASTM A276-410 + STL.	-----
3	Compuerta / Wedge	ASTM A182 F6a	-----
4	Eje / Stem	ASTM A276 - 410	-----
5	Junta Cuerpo / Body Gasket	Inox. / S.S 304 + graphite	-----
6	Tornillo tapa / Bonnet Bolt	ASTM A193 Gr. B7	-----

Nº	Denominación / Name	Material	Acabado Superficial / Surface Treatment
7	Tapa / Bonnet	ASTM A105	Fosfatizado / Phosphatized
8	Estopada / Stem packing	Grafito / Graphite	-----
9	Tuerca Eje / Stem Nut	ASTM A276 - 410	-----
10	Volante / Handwheel	Fundición / Cast Iron	Fosfatizado / Phosphatized

## DIMENSIONES GENERALES / GENERAL DIMENSIONS

Ref	Medida / Size	Dimensiones / Dimensions (mm)				Peso / Weight (Kg)
		d	L	H	D0	
2232N 04	1/2"	10.5	79	161	100	2,200
2232N 05	3/4"	13.5	92	163	100	2,395
2232N 06	1"	18	111	196	125	4,110
2232N 07	1 1/4"	24	120	223	160	5,650
2232N 08	1 1/2"	29	120	251	160	6,740
2232N 09	2"	36.5	140	290	180	10,030

## DIAGRAMA DE PERDIDAS DE CARGA / HEAD LOSSES DIAGRAM

( H<sub>2</sub>O – 20 °C Flujo Horizontal / Horizontal flow).

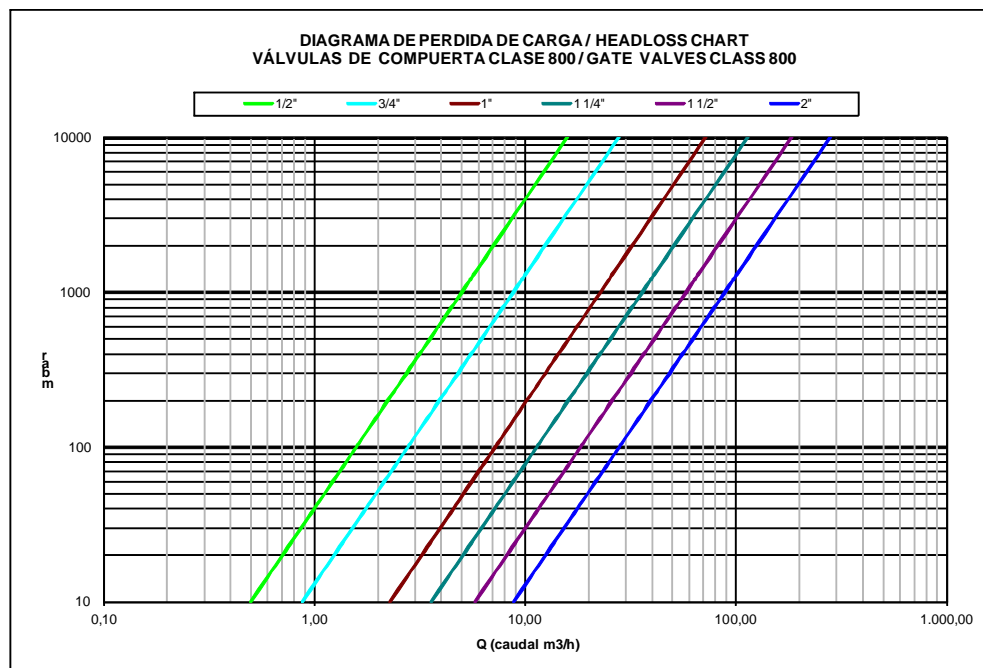

## VALORES DE Kv / Kv VALUES

Kv = Es la cantidad de metros cúbicos por hora que pasará a través de la válvula generando una pérdida de carga de 1 bar.

*Kv = The rate of flow of water in cubic meter per hour that will generate a pressure drop of 1 bar across the valve.*

Med. / Size	1/2"	3/4"	1"	1 1/4"	1 1/2"	2"
m <sup>3</sup> /h	5	8.8	22.8	36.1	57.9	88.2

## CURVA PRESION TEMPERATURA / PRESSURE TEMPERATURE RATING

